



1 SAFETY INSTRUCTIONS

1.1 Caution – Important safety instructions

For reasons of personal safety, it is important to follow all the instructions, as incorrect installation can lead to serious injury. The control box must be installed and adjusted by a professional motorization and building automation installer, in compliance with the regulations of the country in which it is going to be used.

The installation and user manual must be given to the end user, explicitly stating that installation, adjustment and maintenance of the motorization must be performed by a professional motorization and building automation installer.

1.2 Introduction

This control box is designed to control three-phase SIMU motors (<1250W) roll-up or sectional doors in commercial or industrial use. It is provided with 3 push buttons (open / close / stop).

A LED screen allows to check and detect any operating anomalies in the control unit or on the connected devices. This product, installed according to these instructions, complies with EN 12453 et EN 12445. These instructions are especially designed to ensure the safety of property and people.

1.3 Safety instructions relating to installation

⚠ WARNING! An incorrect installation or improper use of the product can cause damages to people, animal or things.

- Scrap packing materials (plastic, cardboard, polystyrene etc.) according to the provisions set out by current standards. Keep nylon or polystyrene bags out of children's reach.
- Keep the instructions together with the technical brochure for future reference.
- This product was exclusively designed and manufactured for the use specified in the present documentation. Any other use not specified in the documentation could damage the product and be dangerous.
- SIMU declines all responsibility for any consequences resulting from improper use of the product, or use which is different from that expected and specified in the present documentation.
- Do not install the product in explosive atmosphere.
- The installation must comply with the provisions set out by the country in which it is going to be used.
- Disconnect the electrical power supply before carrying out any work on the installation. Also disconnect any buffer batteries, if fitted.
- The actuating member of a biased-off switch is to be located within direct sight of the driven part but away from moving parts. It is to be installed at a minimum height of 1,5 m and not accessible to the public.
- For door and gate motors fitted with emergency opening/closing controls, switches must not be positioned higher than 5 feet above ground level.
- If the drive is fitted with a manual release, install its actuating member at a height less than 1,8 m.
- Fit an omnipolar or magneto-thermal switch on the main power supply, having a contact opening distance equal to or greater than 3mm.
- Make sure that there is no crushing between the driven part and the surrounding fixed parts due to the opening movement of the driven part.

- Check that a differential switch with a 0.03 threshold is fitted just before the power supply mains.
- Check that earthing is carried out correctly: connect all metal parts for closure (doors, etc.) and all system components provided with an earth terminal.
- SIMU declines all responsibility with respect to the automation safety and correct operation when other manufacturer's components are used.
- Only use original parts for any maintenance or repair operation.
- Do not modify the automation components, unless explicitly authorized by SIMU.
- Instruct the product user about the control systems provided and the manual opening operation in case of emergency.
- Do not allow people or children to stay in the automation operation area.
- Keep radio control or other control devices out of children's reach, in order to avoid unintentional automation activation.
- The user must avoid any attempt to carry out work or repair on the automation system, and always request the assistance of qualified people.
- Anything which is not expressly provided for in the present instructions is not allowed.

1.4 Safety instructions relating to use and maintenance

WARNING: Important safety instructions. It is important for the safety of people to follow these instructions. Save these instructions.

WARNING: The drive has to be disconnected from its power source during cleaning, maintenance and when replacing parts.

- This system can be used by children aged from 8 years and above and people with reduced physical, sensory or mental capabilities or lack of experience and knowledge if they have been given supervision or instruction concerning use of the appliance in a safe way and understand the hazards involved. Children must not play with the appliance. Cleaning and user maintenance should not be made by children without supervision.
- Do not allow children to play with fixed controls. Keep remote controls away from children.
- Frequently examine the installation for imbalance and signs of wear or damage to cables and springs. Do not use if repair or adjustment is necessary.
- Watch the motorised installation while it is moving and keep people away until the motorised installation is fully extended.
- For drives powered by a very low voltage removable power supply, only the power supply provided with the drive must be used.
- For drives fitted with a manual release, operating conditions are given in the drive instructions.

- ⚠ • All wiring has do be done with power off.
 - PCB protective cover has to be placed before powering on.

1.5 Risk prevention

Risk areas : measures to be taken to eliminate risks

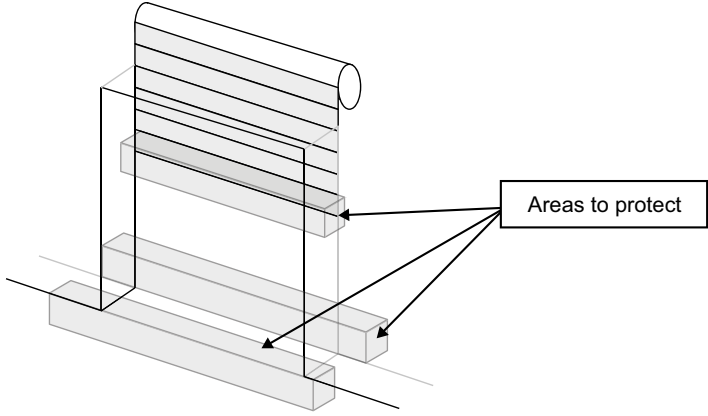
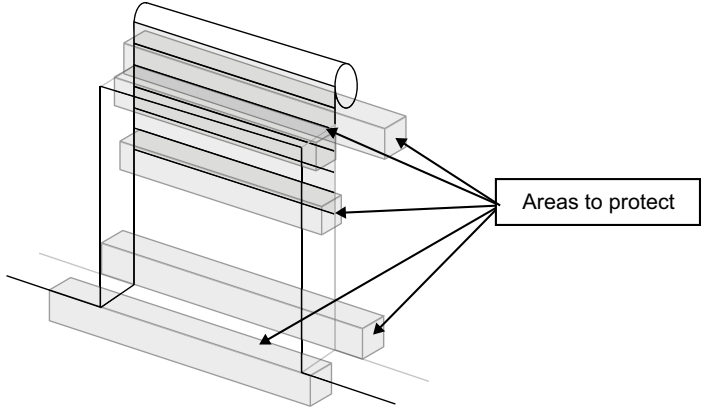
Installation which cannot lift a person or a child	Installation which could lift a person or a child
	
<ul style="list-style-type: none"> • Risk of crushing between the ground and the lower edge of the door during closing. <p>Solution :</p> <ul style="list-style-type: none"> • Obstacle detection using safety edge solution and photocells. <p>Warning : in the case of not self-tested photocells, they must be checked every 6 months.</p>	<ul style="list-style-type: none"> • Risk of crushing between the ground and the lower edge of the door during closing. • Risk of jamming between the case and the door. • Risk of jamming between guides and door. <p>Solution :</p> <ul style="list-style-type: none"> • Photocells (connection on not self-tested input to check every 6 months) • Obstacle detection on the top with self-tested photocells.

2 DESCRIPTION OF SIMUDRIVE SD510 CONTROL BOX

2.1 Reference

DESIGNATION	REF.	
SIMUDRIVE SD510	2008779	

2.2 Technical datas

- Three-phase supply :
 - 230V 3~ 50/60Hz
 - 380-415V 3N~ 50/60Hz
- Maximum power : 1250W
- Accessories power : 24Vdc / 0.5A - 230Vac / 250mA
- Ambient working temperature: +5°C +40°C
- Protection index: IP54
- Dimensions : 221 x 330 x 132 mm
- Weight : 3.2 kg

2.3 Board layout

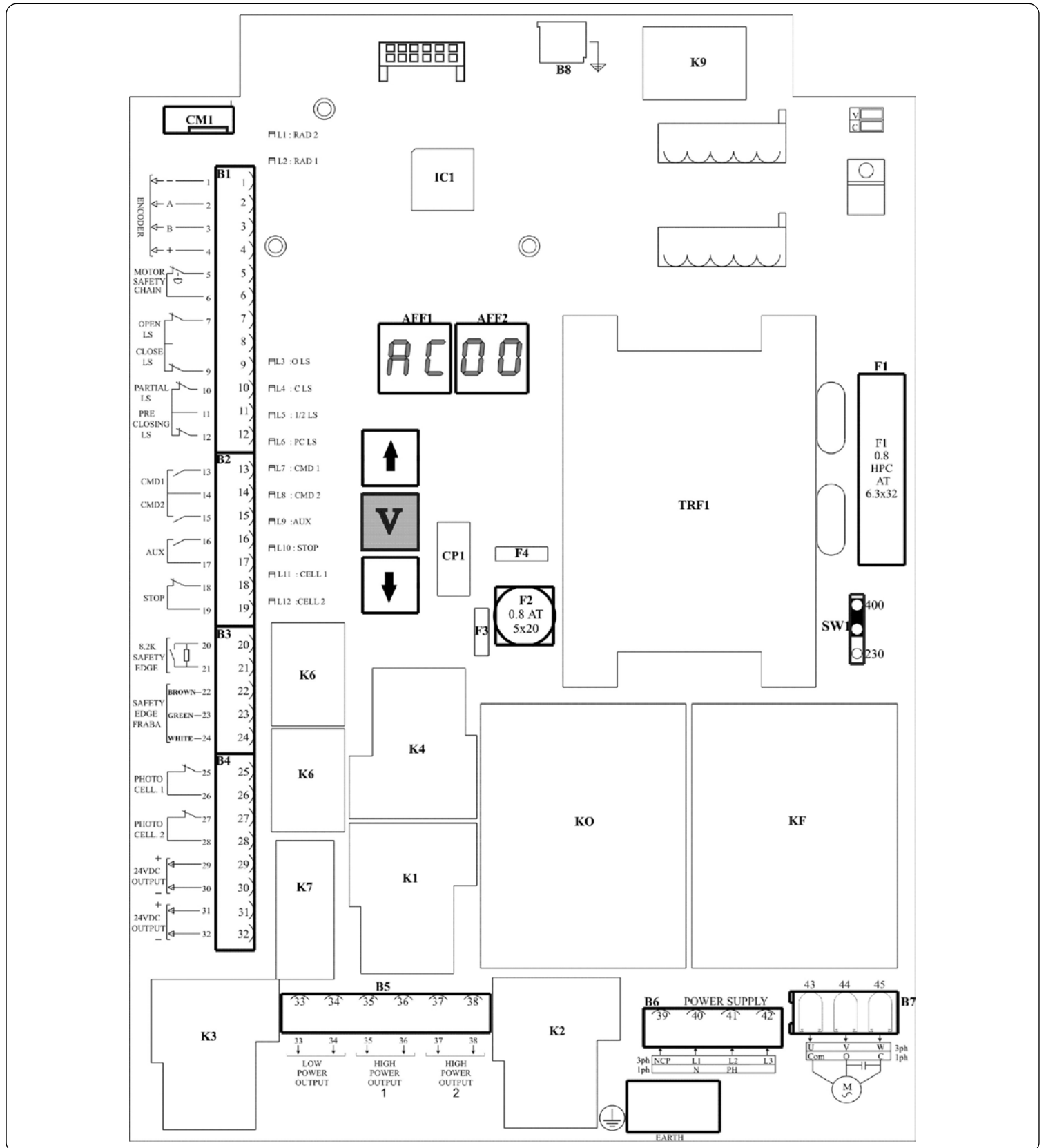

Protective cover : To be used for any handling with power on (settings).

SW1: 230-400: Supply voltage configuration.

V and ↑ ↓ buttons: Navigator menu buttons.

F1: Slow blow fuse 0.8A high breaking capacity / Transformer primary winding protection (H.B.C: High breaking Capacity / 1500A mini).

F2: Slow blow fuse 0.8A / 24 Vdc output protection .

AFF.1: Display shows the operating phase.

AFF.2: Display indicates errors if any, otherwise indicates door position.

B1: Motor encoder output (not used) , End limit contact.

B2: 3 command input (CMD1, CMD2, AUX) , Stop.

B3: Safety edge inputs.

B4: Photocell inputs and 24Vdc 20% / 0.5A global outputs.

B5: Auxiliary outputs

Low power (dry contact). Switchable maximum current: 0.8A at 230Vac or 1.6A at 24Vdc.

2 auxiliary power outputs (dry contact). Maximum voltage and current for change-over switching: 400Vac / 1A

B6: Power supply

B7: Motor output

Led 1 & 2: not used

Led 3: Off if opening limit control input switch is activated

Led 4: Off if closing limit control input switch is activated

Led 5: Off if partial limit switch control input is activated

Led 6: Off if pre-closing limit switch control input is activated

Led 7: On if command 1 control input is activated

Led 8: On if command 2 control input is activated





Led 9: On if auxiliary control input is activated

Led 10: Off if stop or emergency stop control input is activated

Led 11: Off if photocell 1 control input is activated

Led 12: Off if photocell 2 control input is activated

2.4 Description of external programming interface

		Red light, error indicator or maintenance. Blinks to indicate an error (see chapter 4, page 26). Stay on to indicate the necessity of a maintenance.
		To open the door.
		To stop the door.
		To close the door.

2.5 Compatibility and standard installation diagram

The SD510 control box has been designed to control the SIMU T9 and SIMUBOX three-phase motors as well as to be used exclusively with the following SIMU accessories: OSE safety edge, cell barrier, reflex sensor, signalling light, Standard receiver RTS/Hz + TSA + remote control, universal key box, unstable key box, inverters.

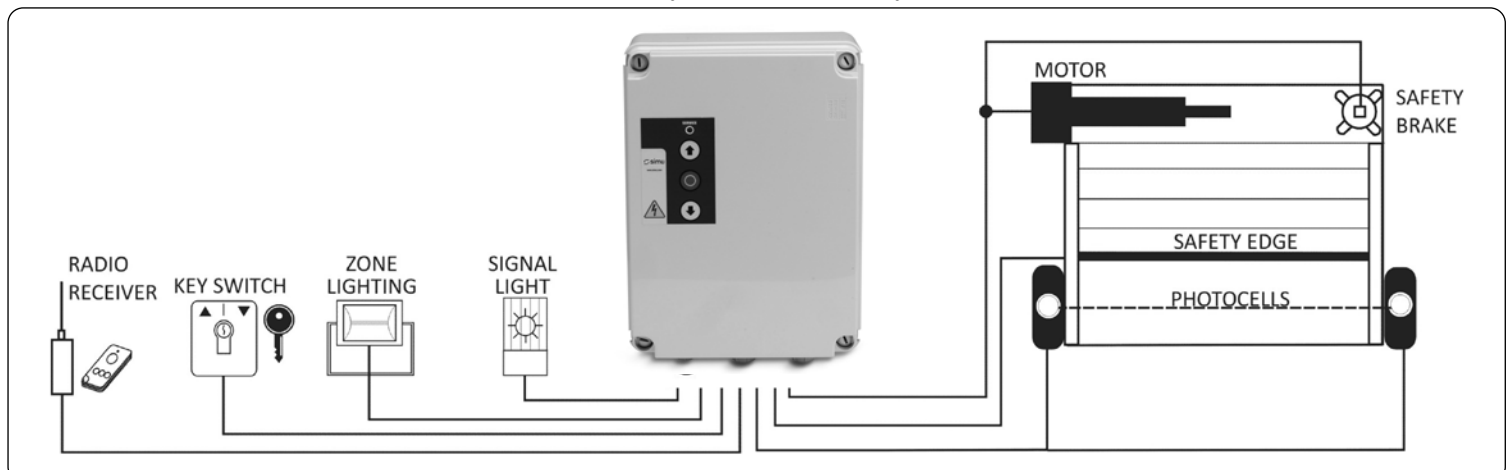

3 MOTOR AND CONTROL BOX CONNECTION

Power off, unscrew the protective cover to access to the PCB.

3.1 Control box supply

- Set up power supply with the switch SW1.
- Connect power supply.

⚠ All wiring has to be done with power off.

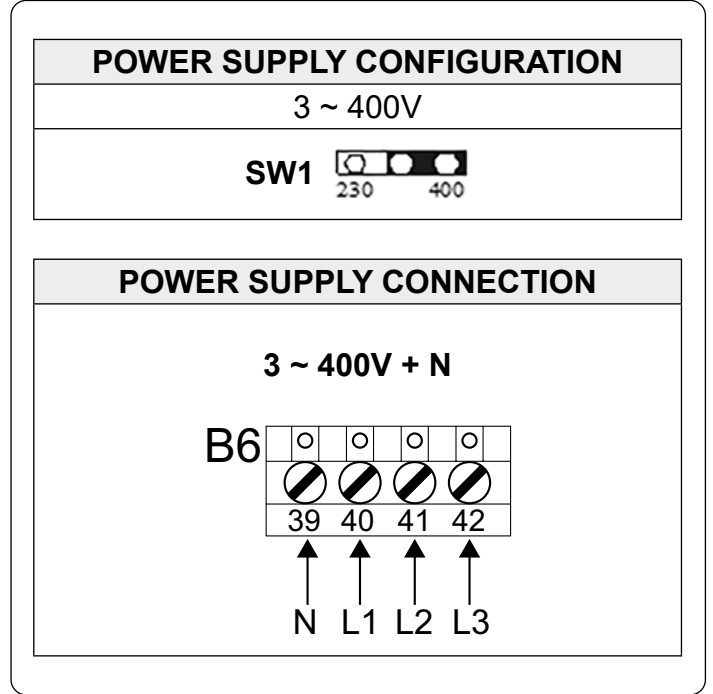
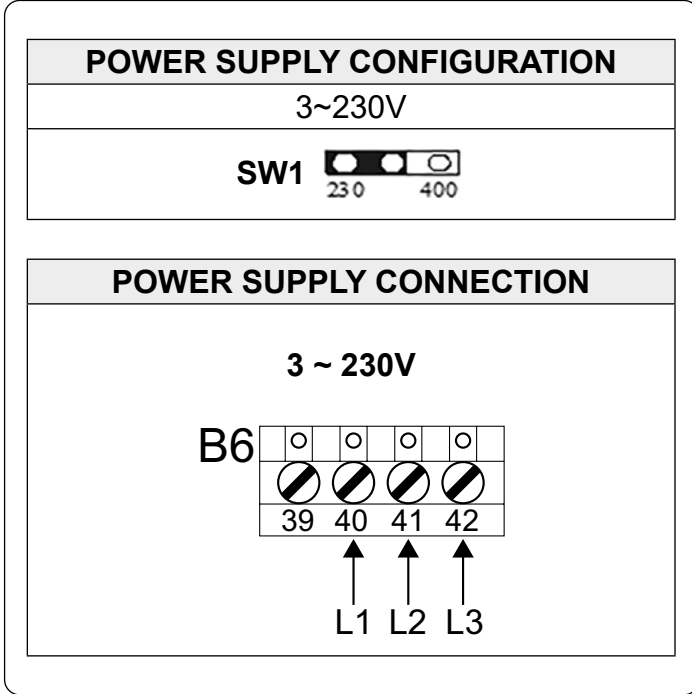

3.2 Motor and safety brake wiring

- Three-phases T9

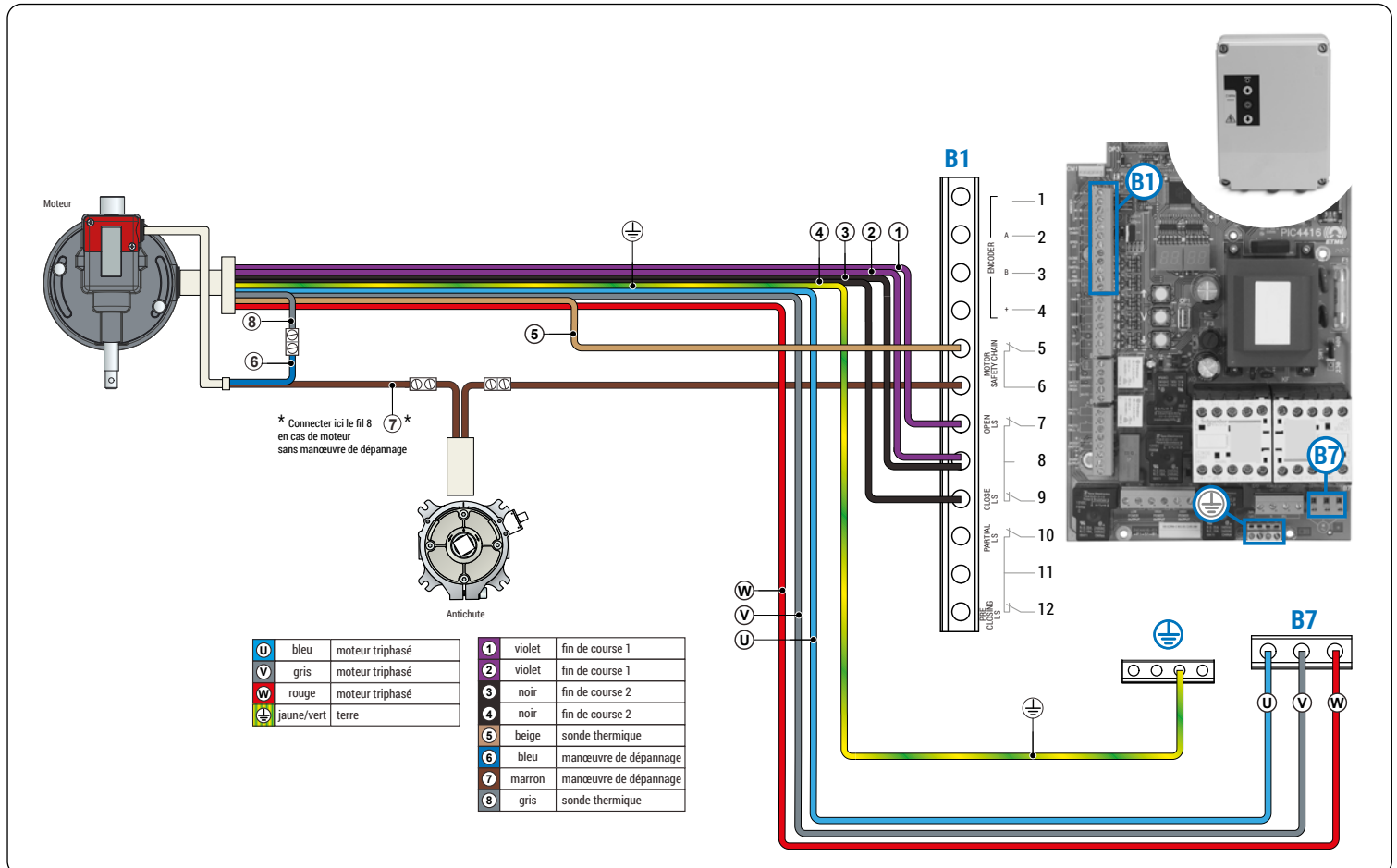

• SIMUBOX three-phase

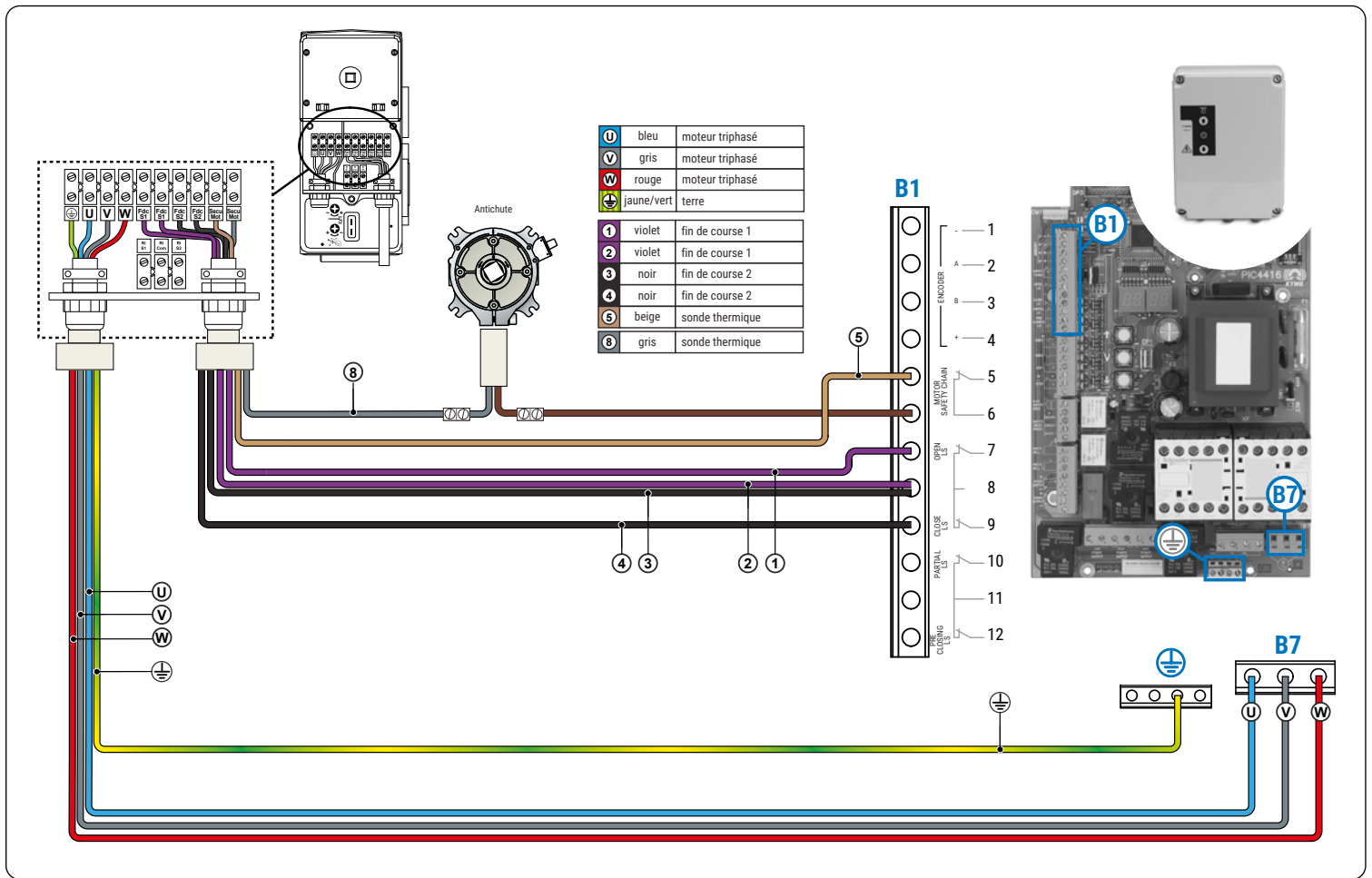

- Connect motor to control box.
- Connection has to be done in a connection box in order not to apply tensile on the cable.
- For a three-phase motor, connect safety brake (compulsory device) in series with motor safety chain and emergency stop (terminals 5 and 6) and connect end limits (terminals 7/8/9).
- Refer to the motor instruction manual for end limits wiring : wires 1/2 from the motor can correspond to opening or closing end limits depending on motor installation (same as wires 3/4).
- Connect an external stop button. Otherwise, use a shunt between 18 and 19. Motor won't work if STOP is not connected.

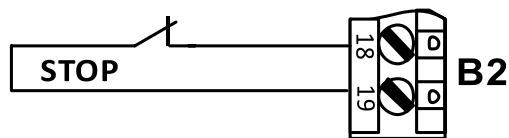

3.3 Checking motor rotation

Replace the PCB protective cover before powering on.

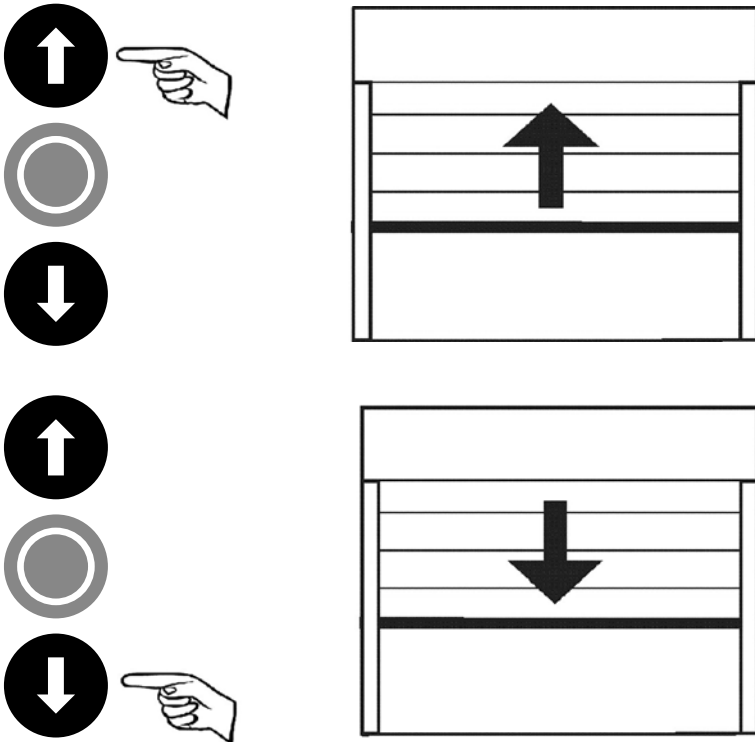

Press and hold the key « up » to open the door.

Press and hold the key « down » to close the door.

If the operation is reversed, power off the product and reverse the motor's power supply.

3.4 End limit settings

The control box is now in dead man mode. Set up end limits with up and down buttons. Check end limit leds lighting.

4 KEY SWITCH CONNECTION

All wirings have to be done with power off.



Description	Reference
UNIVERSAL KEY SWITCH	9012888

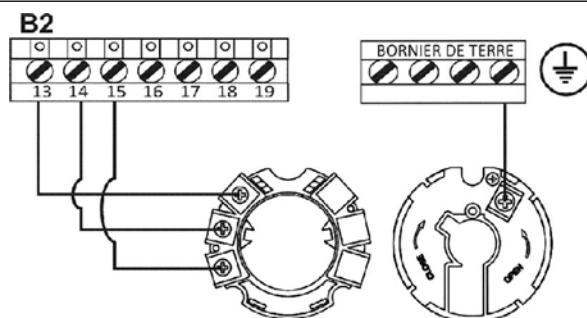

Check the rotation direction. If the axis rotates in the opposite direction to the desired one:

- Stop the movement immediately.
- Turn off power.
- Reverse 13 and 15 on terminal block B2.
- Switch on the system again and repeat the rotation direction check operation.

5 SAFETY ACCESSORIES WIRING

SIMU advices about safety.

OPERATING MODE	KIND OF DOOR	
	SHUTTER WHICH CANNOT LIFT A PERSON	SHUTTER WHICH CAN LIFT A PERSON
MAINTAINED PRESSURE	No accessories required.	No accessories required.
MIXED	No accessories required.	2 sets of self-tested photocells in up position.
IMPULSE/AUTOMATIC	<ul style="list-style-type: none"> • safety edge. • 2 sets of photocells in down position. • flashing light if there is an access to the road. 	<ul style="list-style-type: none"> • safety edge. • 2 sets of photocells in down position. • 2 sets of self-tested photocells in up position. • flashing light if there is an access to the road.

5.1 Optical safety edge wiring

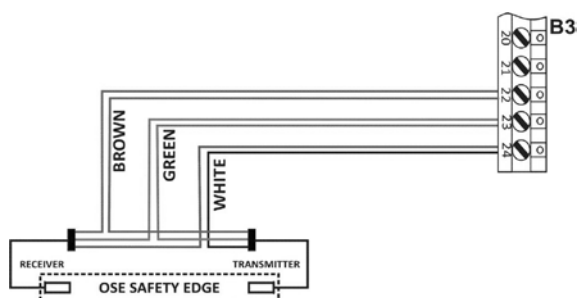

Connections	
B3	OPTICAL SAFETY EDGE
22	BROWN
23	GREEN
24	WHITE

5.2 Photocell wiring

5.2.1 In the case of a shutter which cannot lift a person

2 sets of not self-tested photocells in down position.

When photocells are not self-tested, they must be checked every 6 months.



Description	Reference
Cell Master Pro Bitech	2009527

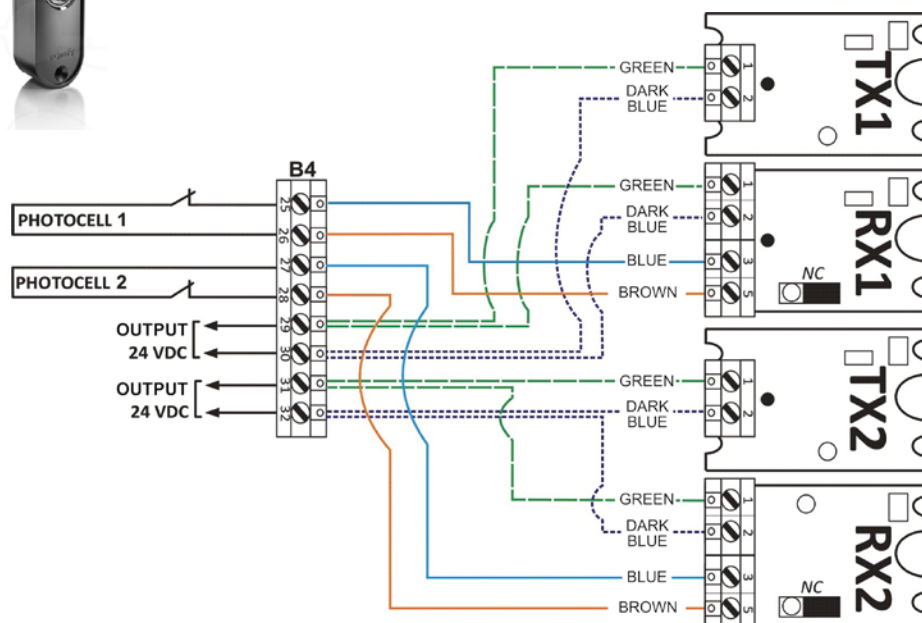

Connections	
B4:25	RX1:3
B4:26	RX1:5
B4:27	RX2:3
B4:28	RX2:5
B4:29	TX1:1
B4:29	RX1:1
B4:30	TX1:2
B4:30	RX1:2
B4:31	RX2:1
B4:31	TX2:1
B4:32	TX2:2
B4:32	RX2:2

5.2.1 In the case of a shutter which can lift a person

2 sets of not self-tested photocells in down position.

When photocells are not self-tested, they must be checked every 6 months.

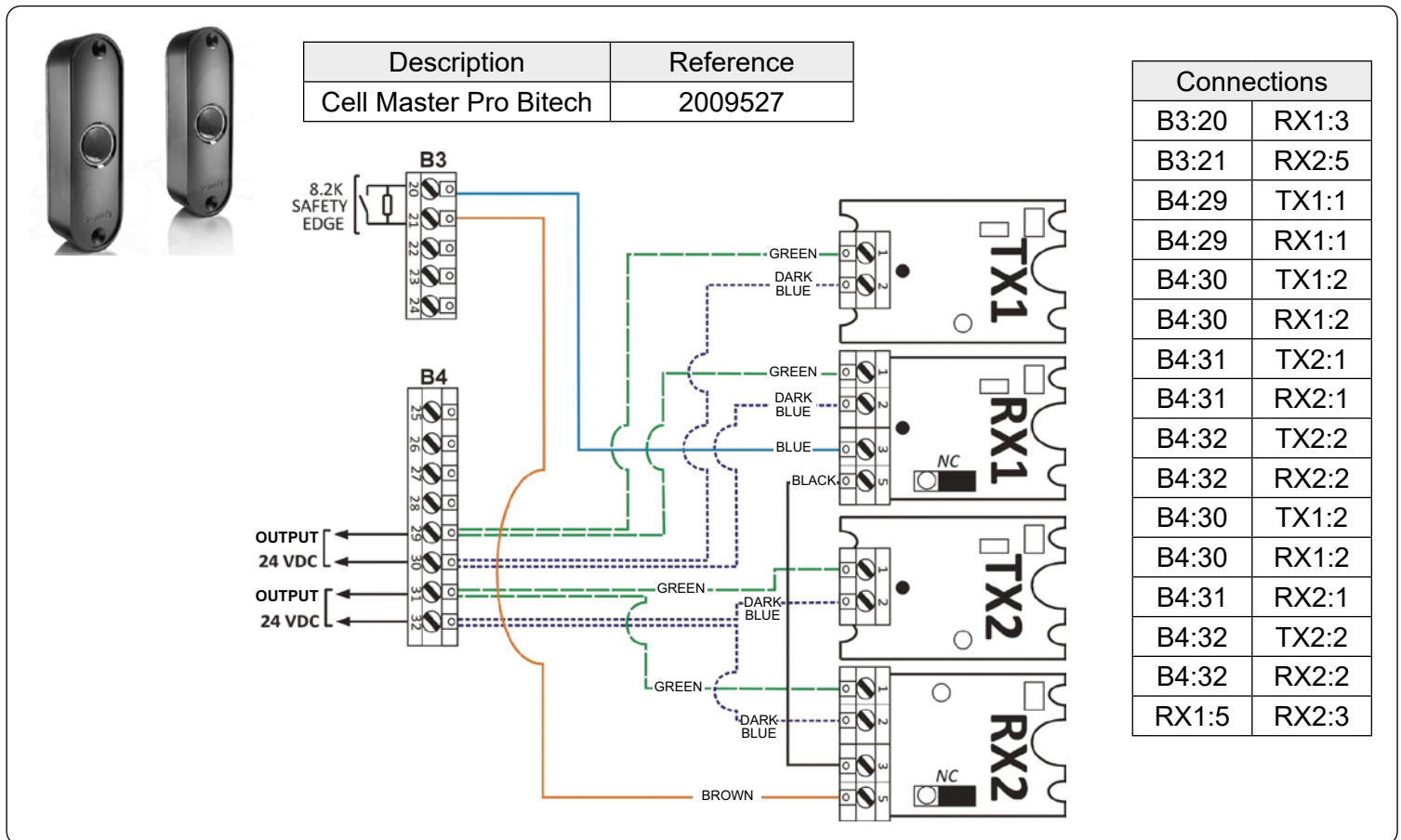

2 sets of self-tested photocells in up position.

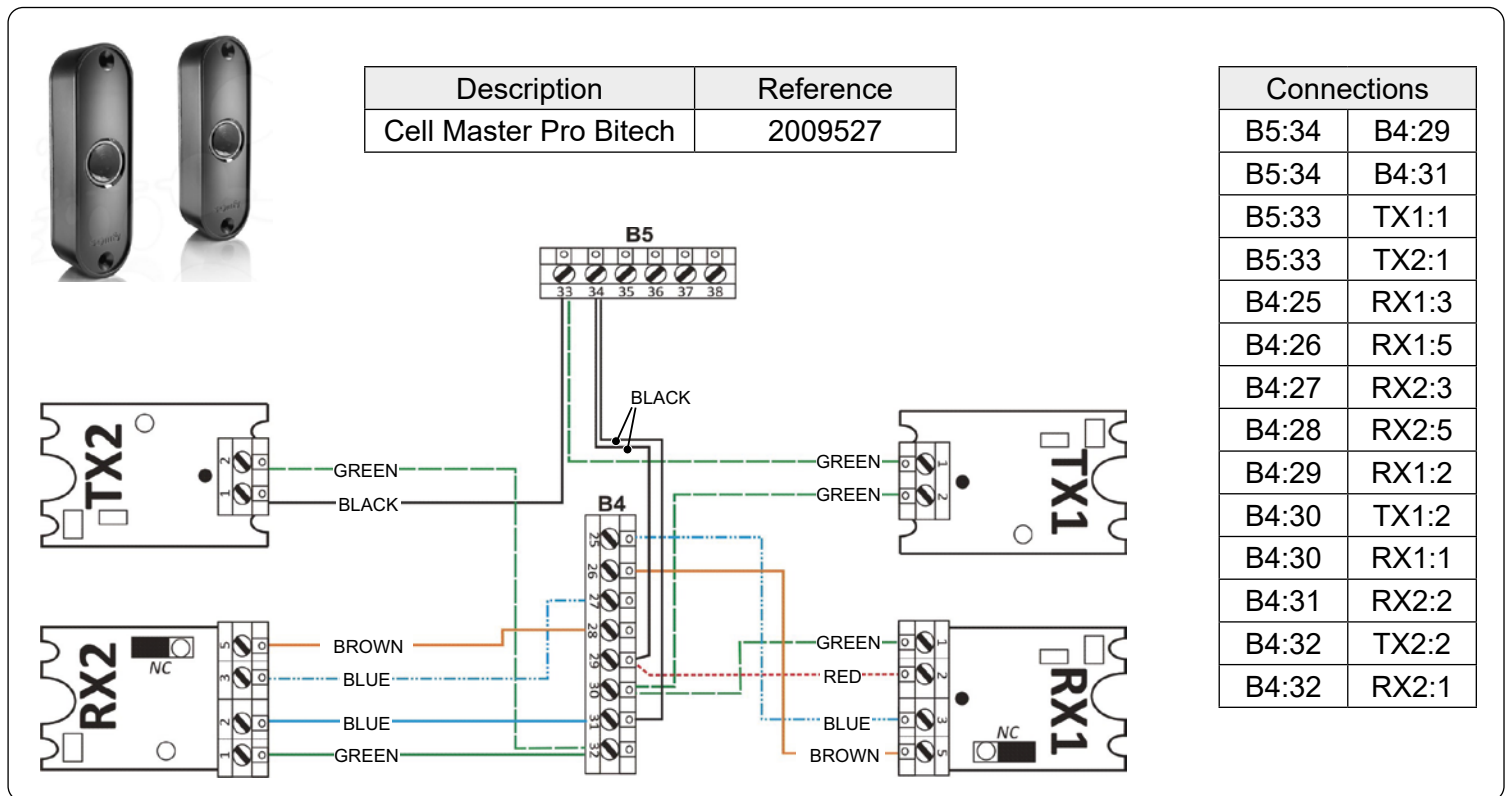

5.3 Flashing light wiring



Description	Reference
MASTERPRO 24V ORANGE LIGHT	9026384

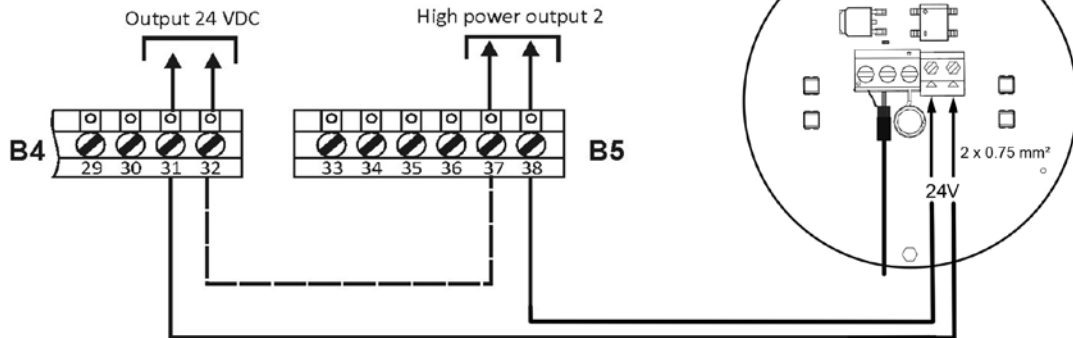

5.4 Lighting wiring

Configure the high power output 1 :

- Flashing output, J1 = 04
- J4=02 (expert mode needed : see chapter 4 p.18)

If a flashing light is also connected place its switch on « FLASH »

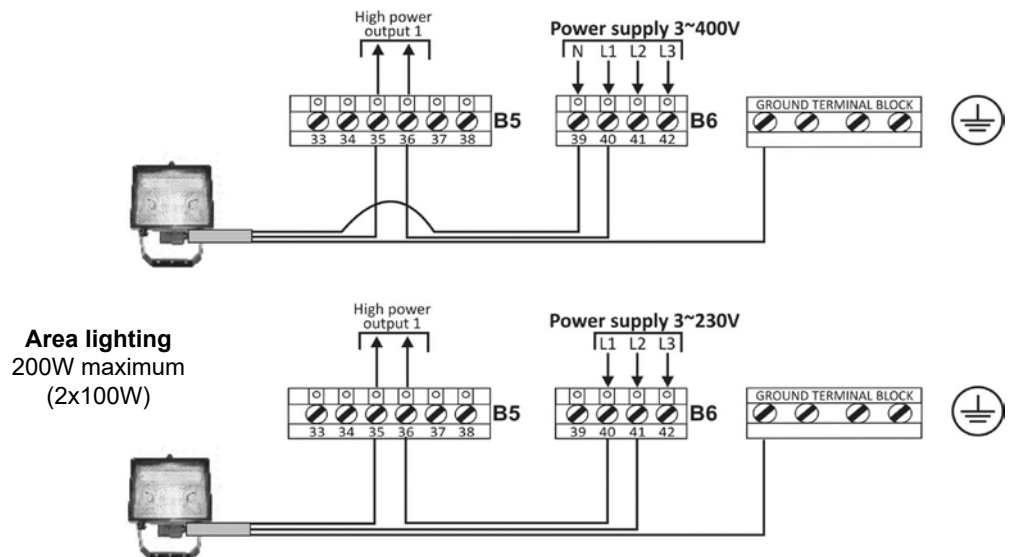

When all wirings are done, replace the protective cover before powering on.

6 FIRST POWER UP

6.1 Display

The 2 digits on the left display the current phase :

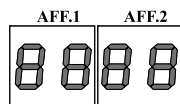

The 2 digits on the right display :

- The default if there is one
- The door position in other case

OPERATING PHASE DISPLAY	
Waiting for a command	AC
Total internal opening (complete opening phase with priority to inside panel)	OU
Total external opening (complete opening phase with priority to outside panel)	OE
Closing (Closing phase in progress)	FE
Waiting to close (Door open, on standby for closing)	AF
Reopening after safety close detection	LO
Reclosing after safety open detection	LF

DOOR POSITION DISPLAY	
00	Door is opened
00	Door is neither opened or closed
00	Door is closed

6.2 First power up procedure

Motor rotation direction has to be checked and the end limits have to be set.

If ATEE error code appears, check end limit wiring (7-8-9), motor safety chain wiring (5-6), stop wiring (18/19) as well as front face button wiring (CM1).

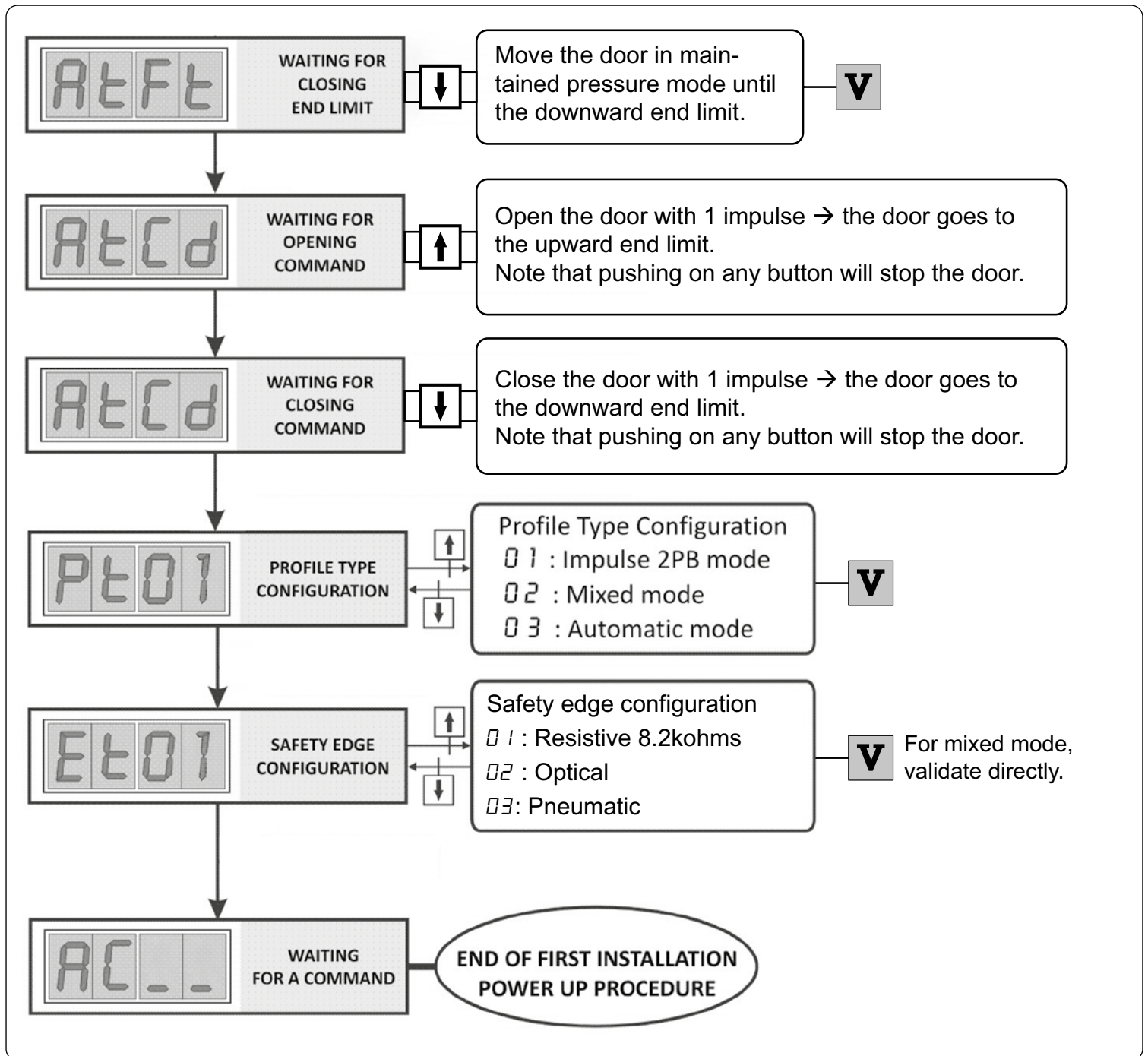

6.3 Button and display operation

Changes have to be done when the curtain is closed.

Example to modify *d1* parameter in « 03 »

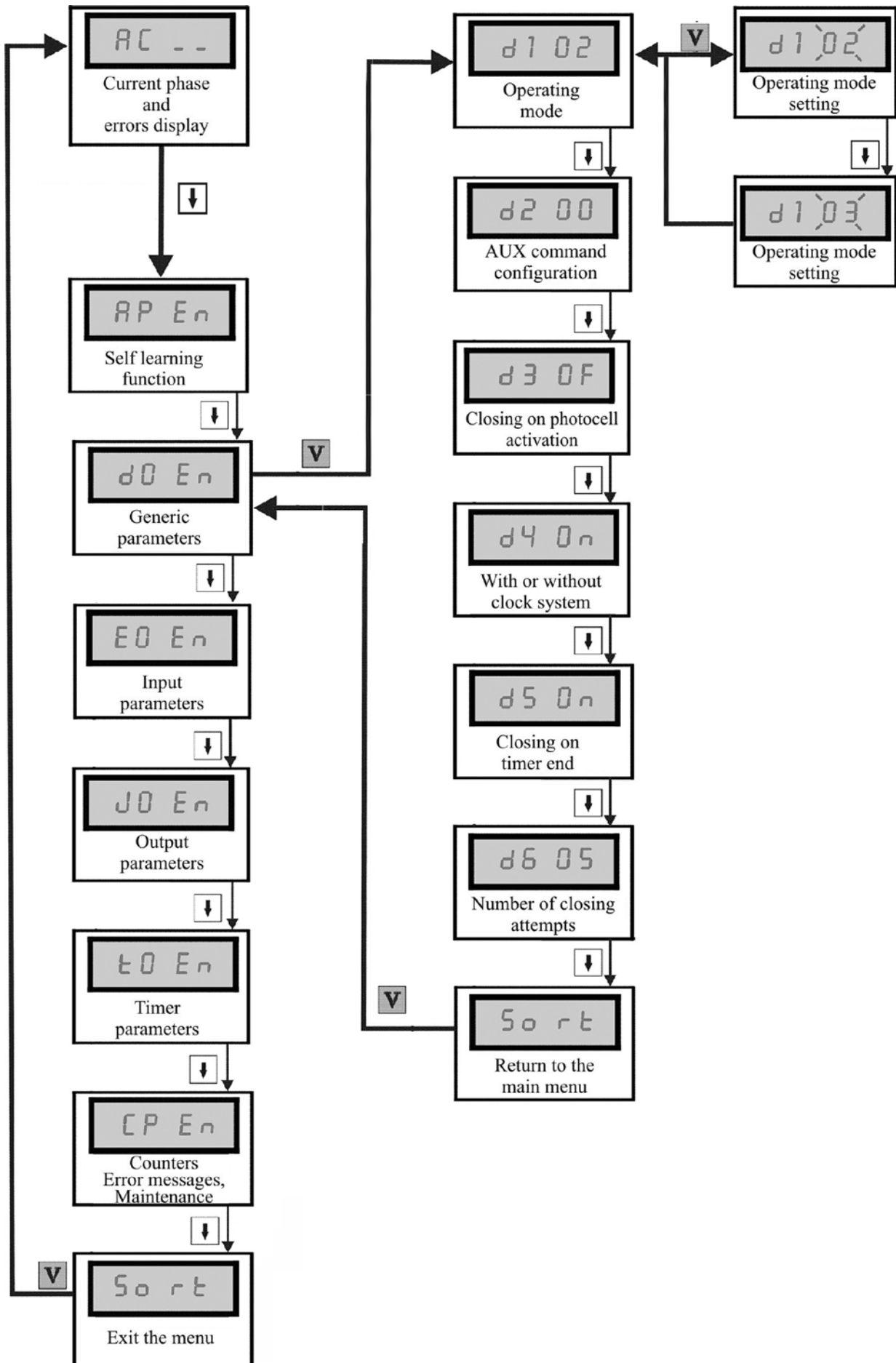

6.4 End limit self learning

Use self-learning if you want to change closed and opened position or learn new operation time. Before starting self-learning process, the installation has to be finished (door installed).

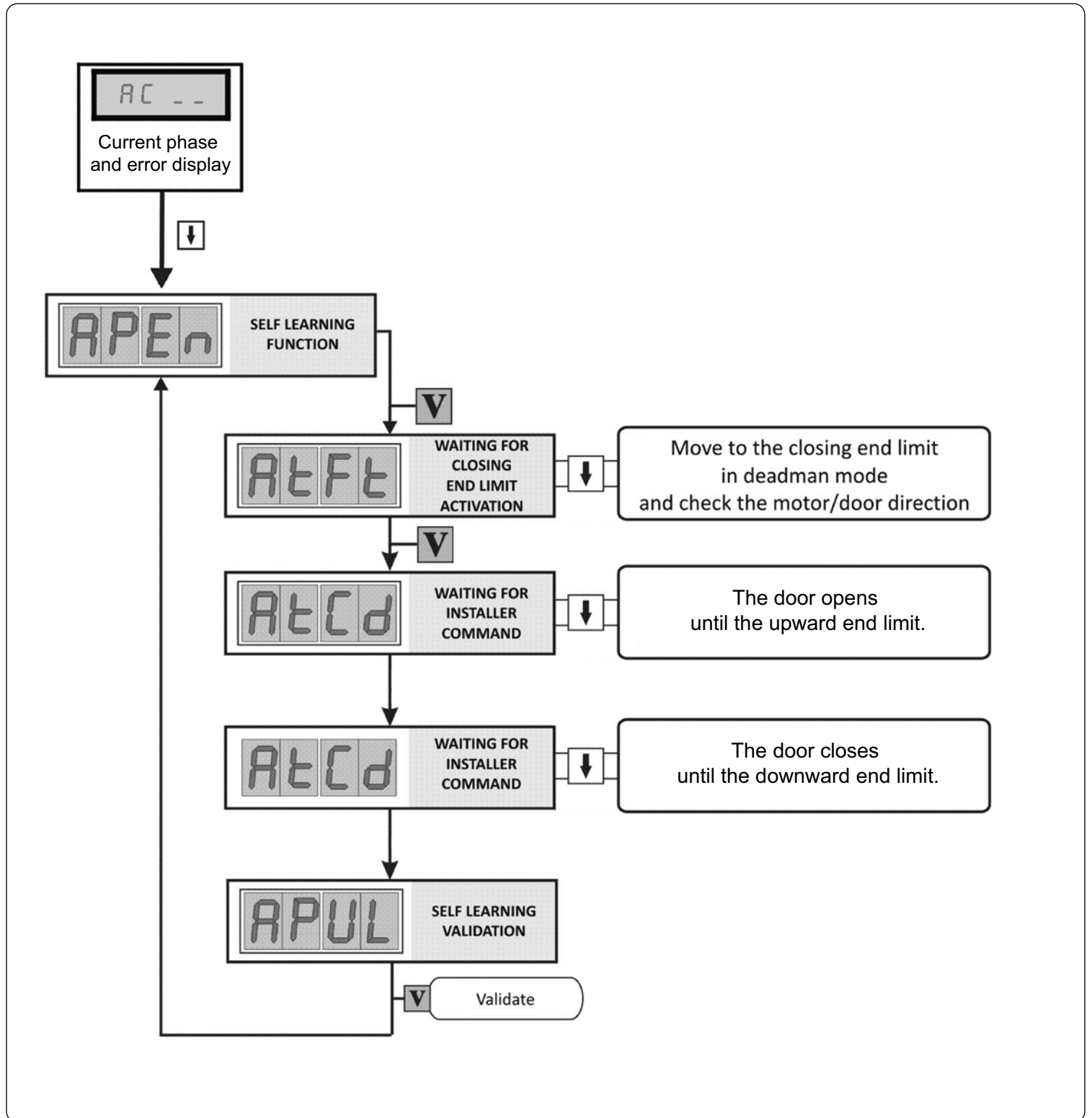

7 SETTINGS IN LEVEL 1

Below tables show pre-programmed parameters. To modify them, refer to 6.3 paragraph (page 13). To make a more advanced programming, refer to Expert parameters (page 18).

7.1 Generic parameters

<i>d0</i>		GENERIC PARAMETERS				
Parameters		Value		Impulse 2BP	Mixed	Automatic
<i>d1</i>	Operating mode	<i>00</i>	Deadman			
		<i>01</i>	Mixed (automatic open / deadman close)		X	
		<i>02</i>	Impulse open and close		X	X
<i>d2</i>	AUX Command configuration	<i>00</i>	Step by step command	X		
		<i>01</i>	Partial / complete opening selection for CMD1			
		<i>02</i>	Partial open command		X	
		<i>03</i>	Traffic management external command			
		<i>04</i>	Input photocell blanking			X
		<i>05</i>	Automatic interlocking input			
<i>d3</i>	Closing on photocell activation	<i>0n</i>	Closing after photocell activation			X
		<i>0F</i>	No closing after photocell activation	X	X	
<i>d4</i>	Closing on timer end	<i>0n</i>	Closing after end of the timer			
		<i>0F</i>	No closing after end of the timer	X	X	X
<i>d5</i>	With or without clock system	<i>0n</i>	With clock system			
		<i>0F</i>	Without clock system	X	X	X
<i>db</i>	Number of closing attempts	<i>00</i> to <i>50</i>	Closing attempts	<i>03</i>	<i>00</i>	<i>03</i>

d1 : Operating mode is preprogrammed during 1st power up procedure. It can be changed in deadman, mixed or impulse. This mode is allowed only with necessary security devices.

d2 : Step by step command allows to control the shutter from a SIMU remote control (installation of standard receiver RTS/HZ below).

Connection of SIMU radio receiver:

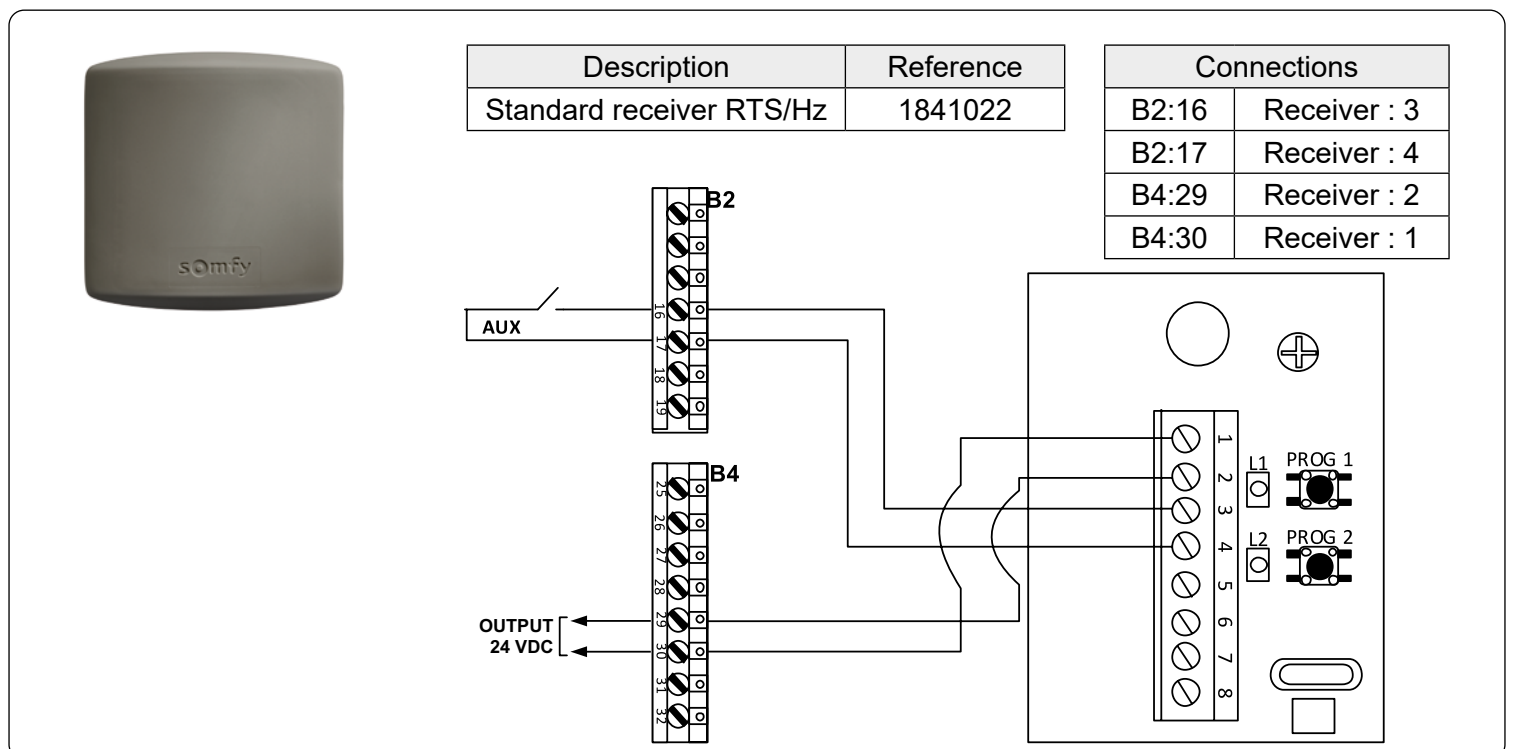

d3 : Possibility to program closing on cell-activation. This mode is only allowed with necessary security devices.

d4 : Shutter can close automatically after a dwell-time. This mode is only allowed with necessary security devices. In this case, check tA in $t0$ menu:

t0						
Parameters		Value		Impulse 2BP	Mixed	Automatic
tF	Opening / closing timer	00	00 second to 4.0 minutes	1.0	1.0	30
tA	Re-closing timer	01	00 second to 4H00	10	10	05
tU	Warning timer before starting	02	00 second to 10 seconds	03	03	03

SETTING TIME t3 PROCEDURE

Between 0 sec and 1 min press the button or to increase or decrease the timer by 1s.

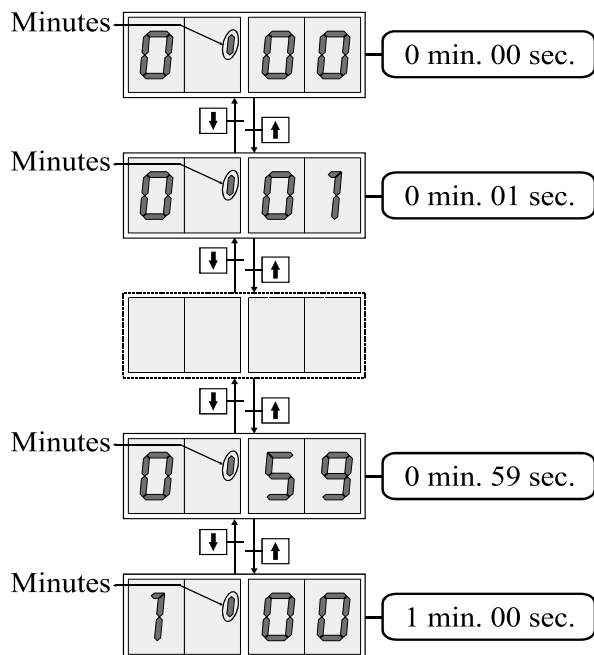

Between 1 min and 10 min press the button or to increase or decrease the timer by 5s.

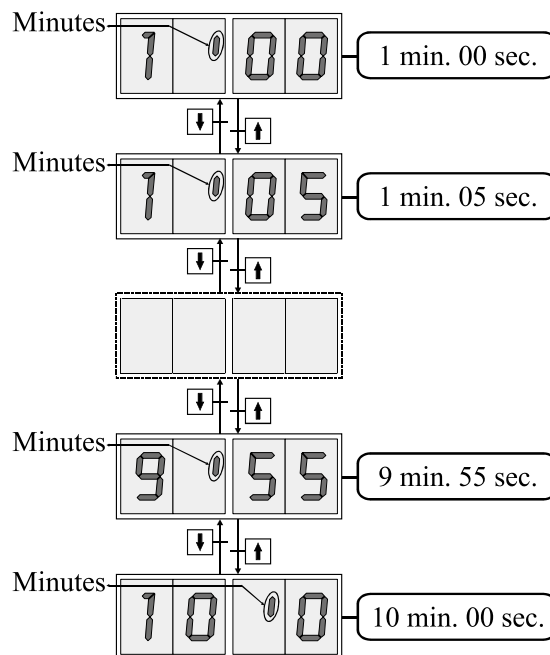

Between 10 min and 1 hour press the button or to increase or decrease the timer by 10 s.

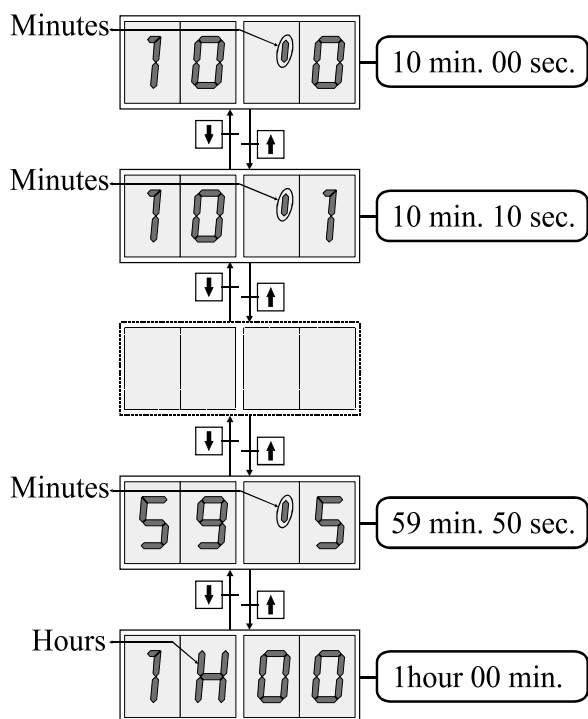

Between 1hour and 4 hour press the button or to increase or decrease the timer by 10 min.

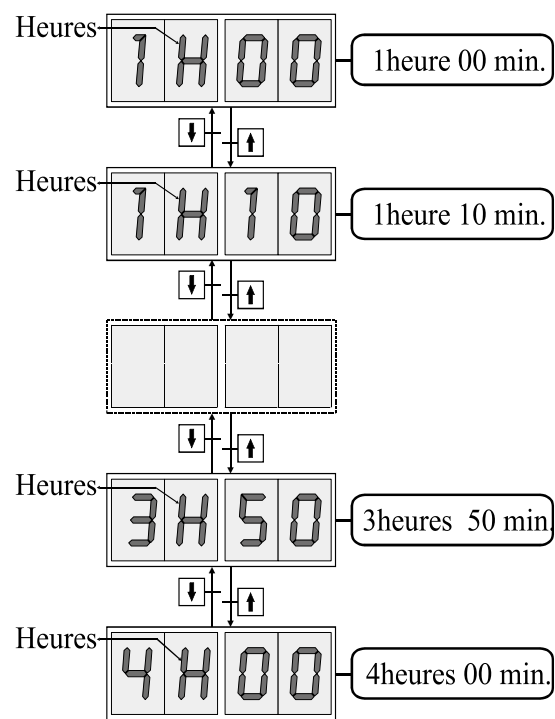

7.2 Input parameters

In the mixed mode, safety devices are not compulsory. As a result, input parameters can only be changed in expert mode (chapter 4).

INPUT PARAMETERS						
Parameters		Value		Impulse 2BP	Mixed	Automatic
<i>E1</i>	Photocell 1 input	EXPERT MODE to modify		Safety input on CLOSING without self-test with complete reopening	Inactive	Safety input on CLOSING without self-test with complete reopening
<i>E2</i>	Photocell 2 input	EXPERT MODE to modify		Safety input on CLOSING without self-test with complete reopening	Inactive	Safety input on CLOSING without self-test with complete reopening
<i>E3</i>	8.2k safety edge input configuration	<i>00</i>	Inactive	Programmed during 1st installation procedure		
		<i>01</i>	8.2k safety edge only			
		<i>02</i>	Air pressure safety edge without 8.2k			
		<i>03</i>	Air pressure safety edge with 8.2k			
		<i>04</i>	Pass-door function			
<i>E4</i>	8.2k safety edge function	<i>01</i>	Safety input on CLOSING with COMPLETE reopening	X	X	X
		<i>02</i>	Safety input on CLOSING with 2 SECONDS reopening			
<i>E5</i>	OSE safety edge function	<i>00</i>	Inactive	Programmed during 1st installation procedure		
		<i>01</i>	Safety input on CLOSING with COMPLETE reopening			
		<i>02</i>	Safety input on CLOSING with 2 SECONDS reopening			
<i>E6</i>	End limit type	<i>00</i>	Mechanical end limit	Programmed during 1st installation procedure		
		<i>01</i>	Electronic end limit			
		<i>02</i>	No end limit			
<i>EF</i>	Radio channel reaction during opening	EXPERT MODE to modify		Reverse		
<i>EH</i>	Function not used					
<i>EJ</i>	Function not used					

In the case of a shutter which can lift a person, the 5 safety accessories have to set like this :

- Bottom photocells are connected on safety edge input : program E3 on 02 (air pressure safety edge without 8.2k).
- Top photocells are self-tested : program E1 and E2 on 04 (cf Chapter 4 to go in expert mode).

7.3 Output parameters

OUTPUT PARAMETERS							
Parameters		Value		Impulse 2BP	Mixed	Automatic	
J1	High power output 1 function	00	Electric strike door release				
		01	Electromagnetic door lock				
		02	Brake contact NO	X	X	X	
		03	Brake contact NC				
		04	Flashing output				
		05	Door closed indication				
J2	High power output 2 function	00	Electric strike door release	X			
		01	Electromagnetic door lock				
		02	Brake contact NO				
		03	Brake contact NC				
		04	Flashing output		X	X	
		05	Door closed indication				
J3	Function not used						
J5	Warning before starting	00	No warning before starting				
		01	Warning before start closing only			X	
		02	Warning before start opening and closing	X	X		
J6	Low power output 1 function	00	Alarm				
		01	Timer				
		02	Door position	X			
		03	Self-test output NC				
		04	Self-test output NO				
		05	Automatic interlocking output				
		06	Buzzer output				
		07	Service point output				
		08	Service point output + deadman operating				
		09	Opened door indication			X	X
		10	Closed door indication				
		11	Function not used				
12	Function not used						
JE	Red traffic lights flashing configuration	EXPERT MODE to modify		Red lights are flashing on the two way			
JF	Red light waiting command configuration	EXPERT MODE to modify		Red lights are off during waiting command phase			

J2 : in impulse mode, change it in 04 to make the signaling light working.

8 EXPERT LEVEL PARAMETERS

8.1 Expert level activation

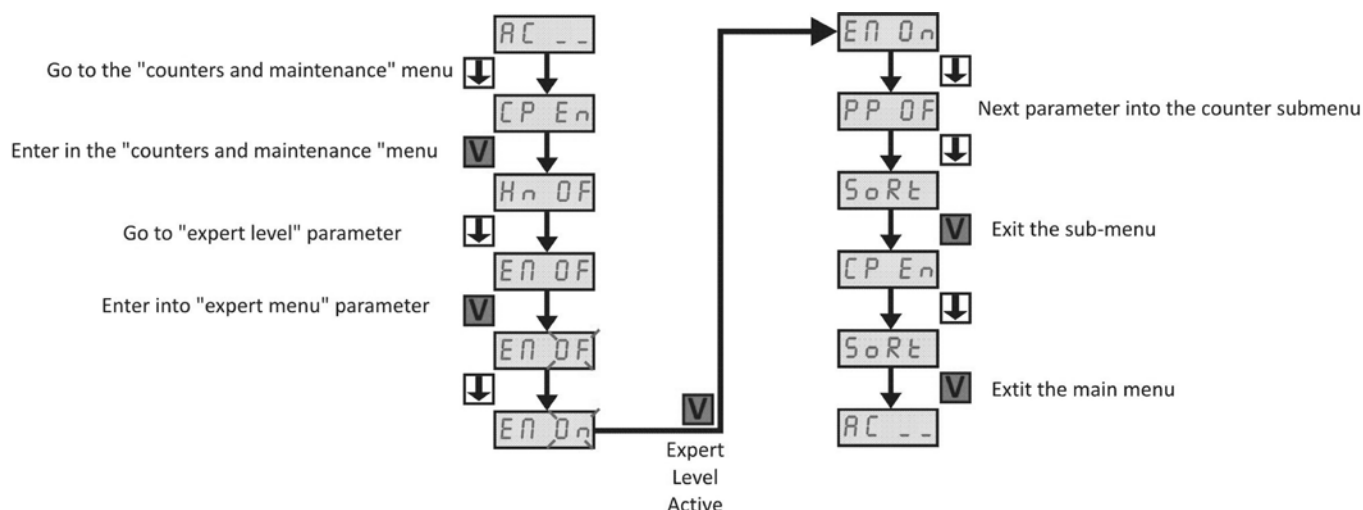

8.2 Expert parameters

GENERIC PARAMETERS						
Parameters		Value		Impulse 2BP	Mixed	Automatic
<i>d1</i>	Operating mode	<i>00</i>	Deadman			
		<i>01</i>	Mixed (automatic open / deadman close)		X	
		<i>02</i>	Impulse open and close	X		X
<i>d2</i>	AUX Command configuration	<i>00</i>	Step by step command	X		
		<i>01</i>	Partial / complete opening selection for CMD1			
		<i>02</i>	Partial open command		X	
		<i>03</i>	Traffic management external command			
		<i>04</i>	Input photocell blanking			X
		<i>05</i>	Automatic interlocking input			
<i>d3</i>	Closing on photocell activation	<i>0n</i>	Closing after photocell activation			X
		<i>0F</i>	No closing after photocell activation	X	X	
<i>d4</i>	Closing on timer end	<i>0n</i>	Closing after end of the timer			
		<i>0F</i>	No closing after end of the timer	X	X	X
<i>d5</i>	With or without clock system	<i>0n</i>	With clock system			
		<i>0F</i>	Without clock system	X	X	X
<i>db</i>	Number of closing attempts	<i>00</i> to <i>50</i>	Closing attempts	<i>03</i>	<i>00</i>	<i>03</i>

E0		INPUT PARAMETERS				
Parameters		Value		Impulse 2BP	Mixed	Automatic
E1	Photocell 1 input	00	Inactive		X	
		01	OPEN safety input without self-test with COMPLETE re-closing			
		02	OPEN safety input without self-test with 2 SECONDS re-closing			
		03	OPEN safety input with self-test with COMPLETE re-closing			
		04	OPEN safety input with self-test with 2 SECONDS re-closing			
		05	CLOSE safety input without self-test with COMPLETE re-opening	X		X
		06	CLOSE safety input without self-test with 2 SECONDS re-opening			
		07	CLOSE safety input with self-test with COMPLETE re-opening			
E2	Photocell 2 input	00	Inactive		X	
		01	OPEN safety input without self-test with COMPLETE re-closing			
		02	OPEN safety input without self-test with 2 SECONDS re-closing			
		03	OPEN safety input with self-test with COMPLETE re-closing			
		04	OPEN safety input with self-test with 2 SECONDS re-closing			
		05	CLOSE safety input without self-test with COMPLETE re-opening	X		X
		06	CLOSE safety input without self-test with 2 SECONDS re-opening			
		07	CLOSE safety input with self-test with COMPLETE re-opening			
E3	8.2k safety edge configuration	00	Inactive	Programmed during 1st installation procedure		
		01	8.2k safety edge only			
		02	Air pressure safety edge without 8.2k			
		03	Air pressure safety edge with 8.2k			
		04	Pass-door function			
E4	8.2k safety edge function	01	Safety input on CLOSING , with COMPLETE re-opening without self-test	X	X	X
		02	Safety input on CLOSING with 2 SECONDS re-opening without self-test			
		03	Safety input : OPENING → STOP , CLOSING → COMPLETE re-opening			
		04	Safety input : OPENING → STOP , CLOSING → 2 SECONDS re-opening			
		05	CLOSE safety input with COMPLETE re-opening and BLANKING			
		06	CLOSE safety input with 2 SECONDS re-opening and BLANKING			
E5	OSE safety edge function	00	Inactive	Programmed during 1st installation procedure		
		01	Safety input on CLOSING , with COMPLETE re-opening without self-test			
		02	Safety input on CLOSING with 2 SECONDS re-opening without self-test			
		03	Safety input : OPENING → STOP , CLOSING → COMPLETE re-opening			
		04	Safety input : OPENING → STOP , CLOSING → 2 SECONDS re-opening			
		05	CLOSE safety input with COMPLETE re-opening and BLANKING			
		06	CLOSE safety input with 2 SECONDS re-opening and BLANKING			
E6	End limit type	00	Mechanical end limit	Programmed during 1st installation procedure		
		01	Electronical end limit			
		02	No end limit			
E7	Function not used					
E8	Function not used					
E9	Function not used					
ER	Function not used					
EC	Function not used					
EJ	Function not used					
EE	Function not used					
EF	Radio channel reaction during opening	00	Stop			
		01	Inversion	X	X	X
EH	Function not used					
EJ	Function not used					

J0		OUTPUT PARAMETERS				
Parameters		Value		Impulse 2BP	Mixed	Automatic
J1	High power output 1 function	00	Electric strike door release			
		01	Electromagnetic door lock			
		02	Brake contact NO	X	X	X
		03	Brake contact NC			
		04	Flashing output			
		05	Door closed indication			
		06	Lock type 1 NO			
		07	Lock type 1 NC			
		08	Lock type 2 NO			
		09	Lock type 2 NC			
		10	Capacitor commutation			
J2	High power output 2 function	00	Electric strike door release			
		01	Electromagnetic door lock			
		02	Brake contact NO			
		03	Brake contact NC			
		04	Flashing output	X	X	X
		05	Door closed indication			
		06	Lock type 1 NO			
		07	Lock type 1 NC			
		08	Lock type 2 NO			
		09	Lock type 2 NC			
		10	Capacitor commutation			
J3	Function not used					
J4	Flashing type	00	Normal speed	X	X	
		01	High speed			X
		02	Fixed			
		03	Impulse 1 second on start			
J5	Warning before starting	00	No warning before starting			
		01	Warning before start closing only			X
		02	Warning before start opening and closing	X	X	
J6	Low power output 1 function	00	Alarm			
		01	Timer			
		02	Door position	X		
		03	Self-test output NC			
		04	Self-test output NO			
		05	Automatic interlocking output			
		06	Buzzer output			
		07	Service point output			
		08	Service point output + deadman operating			
		09	Opened door indication		X	X
		10	Closed door indication			
		11	Function not used			
		12	Function not used			
J7	Function not used					
J8	Function not used					
J9	Function not used					
JR	Function not used					
JB	Function not used					
JC	Function not used					
JD	Function not used					
JE	Red traffic lights flashing configuration	00	Fixed red lights			
		01	Red lights flash on the two ways.	X	X	X
		02	The red lights flashes on the priority way			
JF	Red light waiting command configuration	0n	Red lights are on during the waiting command phase			
		0F	Red lights are off during the waiting command phase	X	X	X

TIMER PARAMETERS					
	Parameters	Value	Impulse 2BP	Mixed	Automatic
<i>tF</i>	Opening / closing timer	00 Sec. to 4.0 Min	1.0	1.0	30
<i>tR</i>	Re-closing timer	00 Sec. to 4000	1.0	10	05
<i>tL</i>	Reverse on safety action timer	00 s to 1.5 s	0.2	0.2	0.2
<i>tE</i>	Traffic light timer	00 s to 10 s	10	10	10
<i>tU</i>	Warning timer before starting	00 Sec. to 10 Sec.	03	03	03
<i>t1</i>	Function not used				
<i>t2</i>	Function not used				
<i>t3</i>	Function not used				
<i>t4</i>	Function not used				

MAINTENANCE

1 CONSULTING AND PROGRAMMING MAINTENANCE

MAINTENANCE - COUNTERS - ERROR MESSAGES						
CP	Parameters	Value	Impulse 2BP	Mixed	Automatic	
<i>Hn</i>	Service operating mode	<i>0n</i>	Deadman without active safety input	X	X	X
		<i>0F</i>	Normal operating mode (<i>d l</i>)			
<i>Ɔ</i>	Cycle counter (high part) (hundred thousand, ten thousand, thousand)	<i>000</i> to <i>999</i>				
<i>c</i>	Cycle counter (low part) (hundred, ten, unit)	<i>000</i> to <i>999</i>				
<i>M</i>	Service point intermediate counter (hundred thousand, ten thousand, thousand)	<i>000</i> to <i>999</i>				
<i>m</i>	Service point intermediate counter (hundred, ten, unit)	<i>000</i> to <i>999</i>				
<i>U</i>	Service point intermediate counter Set point adjustment high part	<i>000</i> to <i>999</i>				
<i>u</i>	Service point intermediate counter set point adjustment low part	<i>000</i> to <i>999</i>				
<i>P0</i>	Last default	<i>00</i> to <i>99</i>				
<i>P1</i>	Before last default	<i>00</i> to <i>99</i>				
<i>P2</i>		<i>00</i> à <i>99</i>				
<i>P3</i>		<i>00</i> à <i>99</i>				
<i>P4</i>		<i>00</i> à <i>99</i>				
<i>P5</i>		<i>00</i> à <i>99</i>				
<i>P6</i>		<i>00</i> à <i>99</i>				
<i>P7</i>		<i>00</i> à <i>99</i>				
<i>P8</i>		<i>00</i> à <i>99</i>				
<i>P9</i>	Oldest default	<i>00</i> à <i>99</i>				
<i>PE</i>	Erase the ten last defaults	<i>0n</i>	Erase defaults			
		<i>0F</i>	Keep defaults			
<i>EM</i>	Expert menu activation	<i>0n</i>	Second level programming			
		<i>0F</i>	First level programming			
<i>PP</i>	Password protection	<i>0n</i>	Active protection code			
		<i>0F</i>	No password protection			
<i>PC</i>	Password change	<i>0n</i>	Start changing password procedure			
		<i>0F</i>	No change			
<i>Fr</i>	Factory reset	<i>0n</i>	Factory reset			
		<i>0F</i>	No factory reset			

SERVICE OPERATING MODE : *Hn*

0n : Allows to configure the door in service operating mode. (Deadman without active safety input).

0F : Normal operating function configured by *d l* parameter

TOTAL NUMBER OF CYCLES: *Ɔ* and *c*

Ɔx xx : Displays hundred of thousand, ten thousand and thousand for the total cycle number.

cx xx : Displays the hundred, ten, and unit for the total number counter.

Example: *260585* cycles done => *Ɔ=260* et *c=585*

SERVICE POINT ADJUSTEMENT VALUE U and u

U and u program a cycle number bracket before next maintenance:

$Ux\ xx$: Allows to configure the number before until the next cycle (High part).

$ux\ xx$: Allows to configure the number before until the next cycle (low part).

Example to adjust 40 000 cycles :

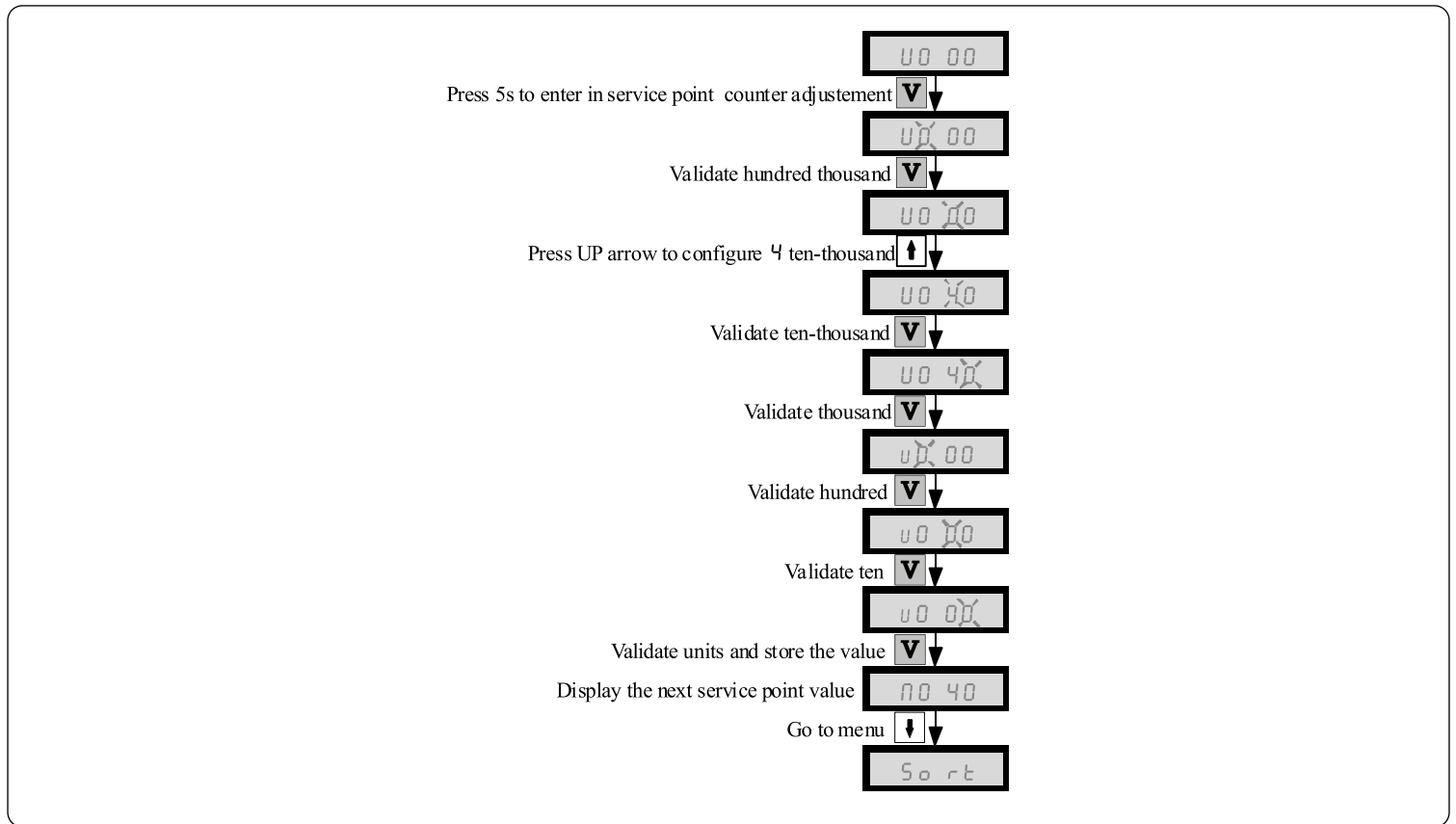

NEXT MAINTENANCE CYCLE COUNTER : M et m

M and m show the cycle number to reach to make the next maintenance. $Mm = Cc + Uu$

$Mx\ xx$: Displays hundred of thousand, ten-thousand and thousand for the next service point value.

$mx\ xx$: Displays hundred, ten and units for the next service point value.

The number of cycles of the next maintenance mn

= Number total of cycles Cc + Service point adjustment value Uu

This function can be associated with a low power output (parameters Ub , $J9$, Ud) configured in maintenance or maintenance + deadman.

If the total number of cycles Cc exceeds the service point adjustment value Mn , the red light on the cover will lit.

DISPLAY THE LAST TEN DEFAULTS : $P0$ to $P9$

Displayed error message	Description
$P0\ xx$	Last displayed error xx = Error message
$P1\ xx$ to $P8\ xx$	Last to old error display
$P9\ xx$	Oldest error display

ERASING THE LAST 10 STORED ERROR MESSAGES : PE

The stored defaults are erased

Next parameter in the sub menu counter

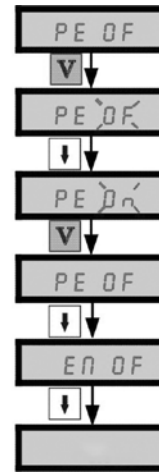

2 2 PASSWORD PROTECTION

PASSWORD PROTECTION ACTIVATION : PP

The password protects the programming menu access.
A reset of the board is necessary for the protection to be active.

Example : password activation 1234

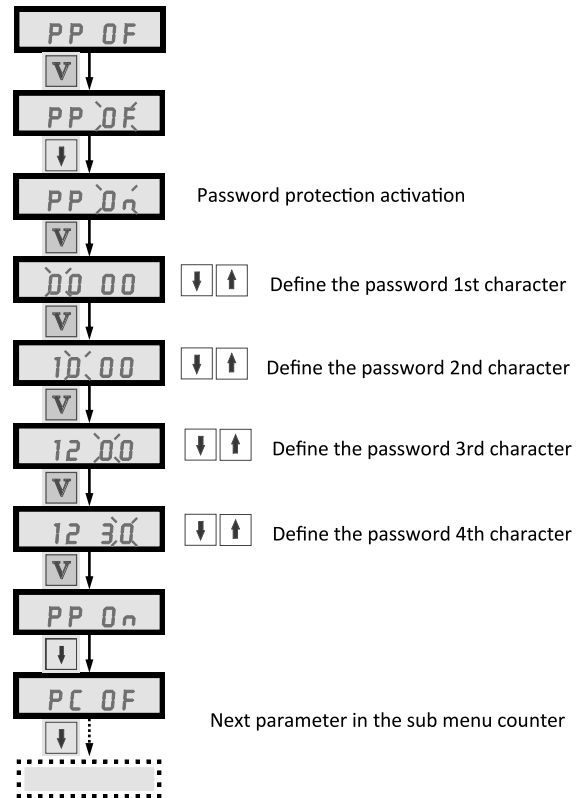

PASSWORD CHANGE : PC

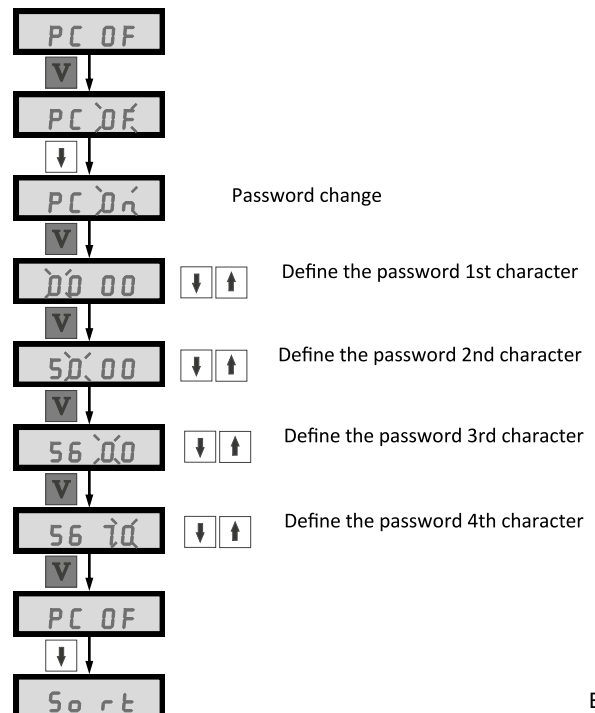

3 FACTORY RESET

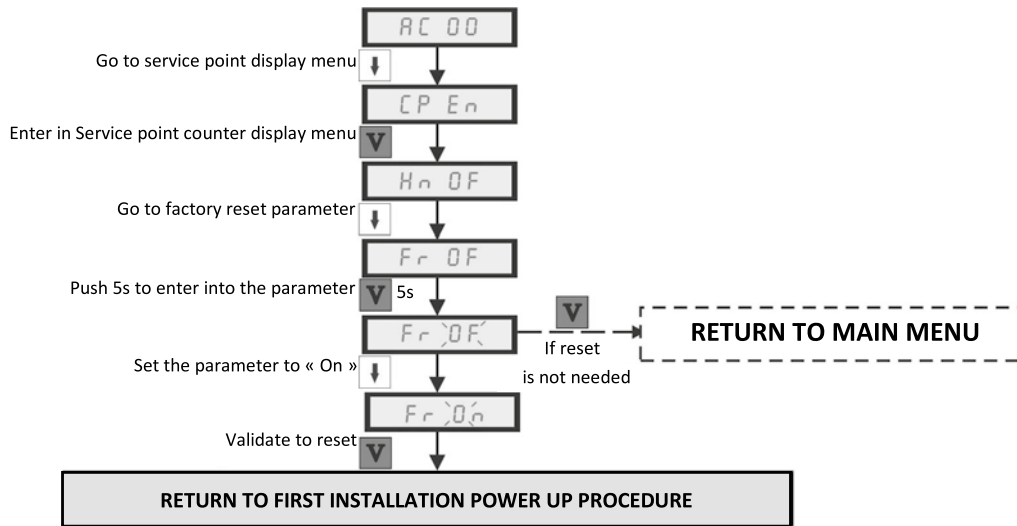

4 ERROR MESSAGES

Error description	Code				Dead Man	Actions and consequences
	Cover Led	Display	Mem.	Alarm		
No error	—	00	No	No	—	
Permanent command	—	10	No	No	—	
Opening command during closing phase	—	11	No	No	—	
Stop \ Safety chain \ Emergency stop	—	12	12	No	—	
Photocell 1 : Opening safety activated	Blinks	20	No	No	Yes	Stay in deadman in opening
Photocell 1 : Closing safety activated	Blinks	21	No	No	Yes	Stay in deadman in closing
Photocell 2 : Opening safety activated	Blinks	22	No	Non	Yes	Stay in deadman in opening
Photocell 2 : Closing safety activated	Blinks	23	No	Non	Yes	Stay in deadman in closing
8.2k safety edge : Opening safety activated	Blinks	24	No	Yes	Yes	Stay in deadman in opening
8.2k safety edge : Closing safety activated	Blinks	25	No	No	Yes	Stay in deadman in closing
OSE safety edge : opening safety activated	Blinks	26	No	Yes	Yes	Stay in deadman in opening
OSE Safety edge : closing safety activated	Blinks	27	No	No	Yes	Stay in deadman in closing
Pass door opened (input 8.2k)	—	28	No	Yes	No	Block all operating function
Self-Testing Photo Cell 1 Error	Blinks	30	30	Yes	Yes	Stay in deadman on the phase where photocell is active until next self test
Self-Testing Photo Cell 2 Error	Blinks	31	31	Yes	Yes	Stay in deadman on the phase where photocell is active until next self test
Air Pressure Safety Edge Diagnostic Error	Blinks	33	33	Yes	Yes	A new air pressure safety self-test is realized during a deadman closing
Pass door failure (8.2k)	—	34	34	Yes	No	Block all operating function Reset needed
Pre-closing area too long	Blinks	35	35	Yes	Yes	
Reset or Power On	—	No	40	Yes	—	
End limit not reached	—	41	41	Yes	—	
Interlocking in progress	—	44	No	No	No	
Buzzer	—	45	No	No	—	
Locking system monitor error	—	46	46	No	—	
Radio receiver : Memory is full	—	50	No	No	No	
Radio receiver : Missing memory	—	51	No	No	No	
Internal Control Error: Internal Board default.	—	60	60	Yes	No	Block all operating function Change control unit
Counter Cycle Overflow	—	65	No	No	No	Change the control unit



SIMU SAS F-70100 ARC-LES-GRAY hereby declares that the product covered by these instructions and used as intended according to these instructions, is in compliance with the essential requirements of the applicable European Directives 2006/42/EC and 2014/30/EU. The full text of the EU declaration of conformity is available on www.simu.com. Bruno Stragliatti, 01/2021.

Somfy limited, Yeadon LS19 7ZA UK, hereby declares that the drive covered by these instructions when marked for input voltage 230V 3~ 50/60Hz or 380-415V 3N~ 50/60Hz and used as intended according to these instructions, is in compliance with UK legislation of Machinery safety regulations S.I.2008 N°1597. The full text of the UKCA declaration of conformity is available at www.somfy.co.uk. Steven MONTGOMERY, Managing Director Somfy Ltd UK & Ireland, Yeadon, 07/22.



We care about our environment. Do not dispose of the appliance with usual household waste. Give it to an approved collection point for recycling.



www.simu.com